

A person wearing a plaid shirt and dark boots is using a long, thin probe to analyze the soil in a field. The field is filled with rows of small green plants. The background shows a bright sky with some clouds.

# Elemental Analysis: CHN characterization of soils and plants using argon as carrier gas

## Authors

Dr. Liliana Krotz, Dr. Francesco Leone and Dr. Guido Giuzzi  
Thermo Fisher Scientific,  
Milan, Italy

## Keywords

Argon, CHN Determination,  
Elemental Analyzer, Helium,  
Plants, Soils

## Goal

This application note shows nitrogen, carbon and hydrogen determination for soils and plants with the FlashSmart EA using argon as carrier gas.

## Introduction

Carbon, hydrogen and nitrogen are regularly characterized in soils and plants to determine agricultural and environmental practices. As the demand for soils and plants testing has grown in the last years, the classical analytical methods showed to be no longer suitable, for their time-consuming sample preparation and for their use of hazardous reagents. For this reason a simple and automated technique is the requirement for modern laboratories dealing with routine analysis.

The Thermo Scientific™ FlashSmart™ Elemental Analyzer (Figure 1), using typically helium gas carrier and based on the dynamic flash combustion of the sample, meets laboratory requirements such as accuracy, day to day reproducibility and high sample throughput. Considering the need for cost efficiencies and the likely increase in helium gas cost, an alternative gas to be used as carrier gas is needed. Argon can be used as alternative to helium in the FlashSmart EA.

This note presents data on CHN determination in soils and plants reference materials with different concentration to show the performance of the system using argon as carrier gas and to show the reproducibility of the results obtained.

## Methods

The FlashSmart Elemental Analyzer operates according to the dynamic flash combustion of the sample. Samples are weighed in tin containers and introduced into the combustion reactor via the Thermo Scientific™ MAS Plus Autosampler together with the proper amount of oxygen. After combustion the resulted gases are carried by an argon flow to the catalyst, a layer filled with copper and then silver cobaltous-cobaltic oxide, then swept through a GC column that provides the separation of the combustion gases, and finally, detected by a Thermal Conductivity Detector (TCD). The analytical configuration as well as the TCD Detector are as the same as those used with helium as carrier gas (see Figure 2).

A complete report is automatically generated by the Thermo Scientific™ EagerSmart™ Data Handling Software and displayed at the end of the analysis. The EagerSmart Data Handling Software provides a new option “AGO” (Argon Gas Option), which allows the modification of the argon carrier flow during the run.



Figure 1. Thermo Scientific FlashSmart Elemental Analyzer.

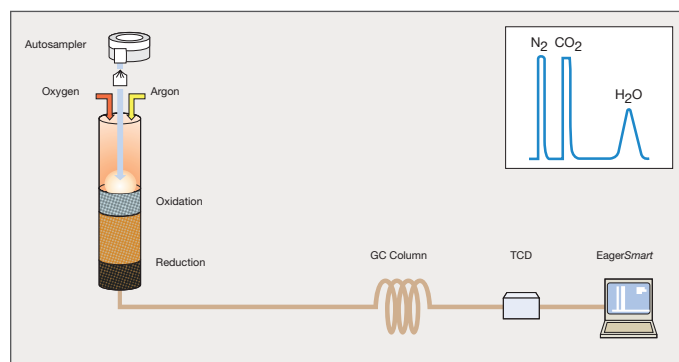

Figure 2. CHN configuration.

### Analytical conditions

Combustion furnace temp.	950°C
Oven temp.	95°C (GC column inside the oven)
Argon carrier flow	70 mL/min
Argon reference flow	70 mL/min
Oxygen flow	250 mL/min
Oxygen injection end	5 sec
Sample delay	12 sec
Run time	10–12 min

## Results

To evaluate the performance of the system for soils and plants analysis, several reference materials with different CHN concentrations were chosen.

Table 1 shows the CHN data obtained of the Thermo Scientific Soil Reference Material (certified values 0.21 N%, 2.29 C%). As the material is certified for nitrogen and carbon and not for hydrogen, the sample was also analyzed using helium as carrier gas to compare the data. With argon as carrier gas, the calibration was performed with 20–50 mg of Thermo Scientific Soil Reference Material and 1–3 mg of Benzoic acid (4.95 H%) using Linear Fit as calibration method. For helium, the system was calibrated with 3–4 mg of Aspartic acid (10.52 N%, 36.09 C%, 5.30 H%) using K factor as calibration method. The Thermo Scientific Soil Reference Material was analyzed in triplicate as unknown to evaluate the repeatability using helium and argon as carrier gas.

Four Soils Reference Materials, certified for nitrogen and carbon, were chosen to correlate the experimental results to the expected values, and as hydrogen is not certified the results were compared with those obtained with helium as carrier gas. Table 2 shows the certified N% and C% and the relative uncertainty. Table 3 shows the weight of sample used and the experimental results obtained with both argon and helium a carrier gas.

A Sandy Soil Reference Material at 0.07 N% (700 ppm N, uncertainty  $\pm 0.01$ ) and 0.83 C% (uncertainty  $\pm 0.05$ ) using argon as carrier gas was analyzed ten times to evaluate the repeatability at low element content. The sample was weighed at 70–80 mg. The data were compared with those obtained using helium as carrier gas, analyzing each sample in triplicate. Table 4 shows the experimental results obtained with both argon and helium a carrier gas. The data obtained meets the specification of the analyzer.

**Table 1. CHN data of Thermo Scientific Soil Reference Material.**

Argon Carrier Gas							Helium Carrier Gas						
Weight (mg)	N%	RSD%	C%	RSD%	H%	RSD%	Weight (mg)	N%	RSD%	C%	RSD%	H%	RSD%
37.671	0.209		2.280		0.898		20.364	0.207		2.293		0.895	
21.001	0.201	1.45	2.292	0.95	0.926	0.89	16.300	0.200	1.85	2.265	0.61	0.888	0.43
28.687	0.220		2.249		0.896		18.681	0.206		2.280		0.889	

**Table 2. Certified NC data of Soil Reference Materials.**

Reference Material Description	Specification			
	N%	Uncertainty ( $\pm$ )	C%	Uncertainty ( $\pm$ )
Low Organic Content Soil Reference Material	0.133	0.023	1.61	0.09
Medium Organic Content Soil Reference Material	0.27	0.02	3.19	0.07
Loamy Soil Reference Material	0.27	0.02	2.75	0.12
Chalky Soil Reference Material	0.35	0.02	5.39	0.09

**Table 3. Experimental CHN data of Soils Reference Materials.**

Reference Material	Argon Carrier Gas							Helium Carrier gas						
	W (mg)	N%	RSD%	C%	RSD%	H%	RSD%	W (mg)	N%	RSD%	C%	RSD%	H%	RSD%
Low Organic Content Soil	48.078	0.116		1.665		0.378		12.635	0.128		1.651		0.360	
	51.860	0.115	0.56	1.653	1.08	0.383	2.01	15.811	0.128	1.36	1.666	0.46	0.365	1.74
	47.413	0.114		1.630		0.355		16.971	0.125		1.660		0.371	
Medium Organic Content Soil	31.443	0.282		3.160		0.692		14.802	0.259		3.173		0.702	
	33.823	0.275	1.30	3.180	0.74	0.675	2.83	15.344	0.256	1.16	3.189	0.73	0.710	0.98
	30.537	0.277		3.216		0.654		14.547	0.262		3.219		0.716	
Loamy Soil	37.536	0.261		2.823		0.661		15.525	0.254		2.751		0.651	
	34.856	0.265	1.33	2.776	0.85	0.645	2.10	14.149	0.260	1.24	2.767	0.39	0.640	0.94
	31.416	0.268		2.792		0.634		16.408	0.258		2.772		0.641	
Chalky Soil	30.631	0.366		5.375		0.859		17.277	0.365		5.401		0.839	
	26.440	0.363	1.12	5.387	0.11	0.852	0.55	17.535	0.363	0.69	5.399	0.52	0.845	0.71
	25.403	0.358		5.381		0.861		18.096	0.360		5.349		0.851	

Table 4. CHN data of Sandy Soil Reference Material.

Argon Carrier Gas							Helium Carrier Gas						
W (mg)	N%	RSD%	C%	RSD%	H%	RSD%	W (mg)	N%	RSD%	C%	RSD%	H%	RSD%
70.086	0.067		0.862		0.205								
72.063	0.069		0.856		0.214								
69.128	0.068		0.867		0.215								
72.088	0.070		0.852		0.205								
71.747	0.068	3.15	0.841	1.87	0.200	3.13	19.326	0.066		0.833		0.183	
73.888	0.071		0.856		0.205		16.183	0.068	1.73	0.865	1.91	0.185	0.83
75.038	0.072		0.832		0.200		16.221	0.066		0.845		0.182	
72.601	0.073		0.880		0.217								
67.502	0.072		0.874		0.213								
81.822	0.073		0.854		0.202								

Table 5. Expected CHN values of Plants Reference Materials.

Reference Material Description	Specification					
	N%	Uncertainty (±)	C%	Uncertainty (±)	H%	Uncertainty (±)
Birch Leaves	2.12	0.06	48.09	0.51	6.55	0.30
Orchard Leaves	2.28	0.04	50.40	0.40	6.22	0.03
Alfalfa Plant	3.01	0.20	N/A	N/A	N/A	N/A

Table 6. Experimental CHN data.

Plant Reference Material	Argon Carrier Gas							Helium Carrier Gas						
	W (mg)	N%	RSD%	C%	RSD%	H%	RSD%	W (mg)	N%	RSD%	C%	RSD%	H%	RSD%
Birch Leaves	2.472	2.157		48.120		6.436		3.099	2.135		48.110		6.483	
	2.662	2.136	0.59	47.999	0.16	6.429	0.12	2.652	2.136	0.31	48.350	0.56	6.489	0.09
	2.823	2.159		47.978		6.421		2.303	2.124		47.860		6.492	
Orchard Leaves	2.686	2.291		50.158		6.248		2.716	2.308		50.210		6.203	
	2.430	2.286	0.20	50.180	0.12	6.232	0.16	3.118	2.292	0.44	50.143	0.09	6.199	0.15
	2.883	2.282		50.064		6.251		2.868	2.289		50.129		6.205	
Alfalfa Plant	2.765	2.990		43.598		6.014		2.806	2.962		43.342		5.959	
	2.849	3.018	0.49	43.710	0.19	6.034	0.25	2.837	3.009	0.88	43.470	0.18	5.926	0.73
	2.771	2.997		43.761		6.005		2.762	3.006		43.480		6.011	

Three Plants Reference Materials were chosen to correlate the experimental results to the expected values and to compare the results using argon or helium as carrier gas. With argon gas, the calibration was performed with 1.5–2 mg of Atropine and 2–4 mg Aspartic acid using Linear Fit as calibration method while for helium gas the calibration was performed with 3–4 mg of Aspartic acid using K factor as calibration method. Table 5 shows the certified values and the relative uncertainty. Table 6 shows the weight of sample

used and the experimental results obtained with both argon and helium a carrier gas. The average of the three runs falls within the uncertainty range.

### Conclusions

Good repeatability, accuracy and precision was obtained with the FlashSmart Elemental Analyzer using argon as carrier gas. This experimental data confirm the high compatibility with the results obtained using helium gas.

Find out more at [thermofisher.com/OEA](http://thermofisher.com/OEA)

**ThermoFisher**  
SCIENTIFIC