

# IMV VIBRATION TEST SYSTEMS

## J series

Air cooled Vibration Test Systems

# J250/SA5M EM2505

# J

Long duration shock tests require high velocity and large displacement. J-series is a high-frequency system that offers usability and durability furnished with functions that accommodates high velocity and displacement testing.

### [Expanded maximum test range]

Max. velocity of Sine force: 2.4m/s • Max. velocity of Shock force 4.6 m/s • Max. displacement: 100mp-p

[Patented upper (armature) support system PS Guide] Parallel Slope Guide is standard.

[Low noise] Optimised design of the air intake based on fluid dynamics has reduced the air-intake noise.

[All models can be directly coupled to a climatic chamber.]



### ① High Velocity and Large Displacement

High velocity of 2.4m/s and Large displacement of 100mmp-p (4 inch).



■ PSG guide system

### ② Improvement of Testing Environment

With the operation of Intelligence Shaker Management (ISM), EM range can reduce power consumption and CO2 emissions automatically.

eco-shaker

### ② User first principle

Compatible with K2 vibration controller. Intuitive interface leads The operator with user-friendly guidance.



# J250/SA5M EM2505



System Specifications		
System Model	J250/SA5M	EM2505
Freq. Range (Hz)	0-2200	
Force	SINE (kN)	35
	RANDOM (kN rms)	35
	SHOCK (kN)	70
Max. Acc.	SINE (m/s <sup>2</sup> )	777
	RANDOM (m/s <sup>2</sup> rms)	544
	SHOCK (m/s <sup>2</sup> )	1555
Max. Vel.	SINE (m/s)	2.4
	Shock (m/s peak)	2.4 <sup>*7</sup>
Max. Disp.	SINE (mmp-p)	100
	MAX. TRAVEL (mmp-p)	120

Vibration Generator (J250)	
Armature Mass (kg)	45
Armature Diameter (φ mm)	440
Armature Resonance (Hz)	1700
Allowance eccentric moment (N.m)	1550
Maximum Payload (kg)	600
Mass (kg)	3500

Cooling Blower		
Model	VAPE 710/P2R	
Mass (kg)	250	
Environmental Data		
Power Requirement (kVA)	53	
Input voltage supply (3 φ, V)	200/220 or 380/400/415/440	
Compressed Air Supply (Mpa)	0.6	
Working Ambient	Temperature (°C)	0 - 40
	Humidity (%RH)	0 - 85

Power Amplifier		
System Model	SA5M-J50	SA5M-J50EM
Max. Output [kVA]	50	50
Mass [kg]	880	930

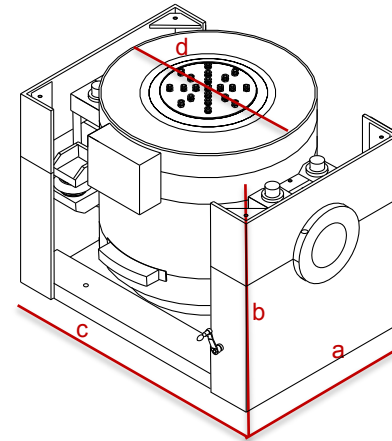

**Shaker**  
Model: J250

- a: W 1463mm
- b: H 1301mm
- c: D 1100mm
- d: 860φmm

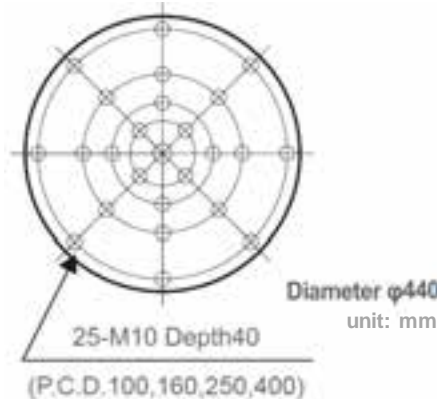

**J250**

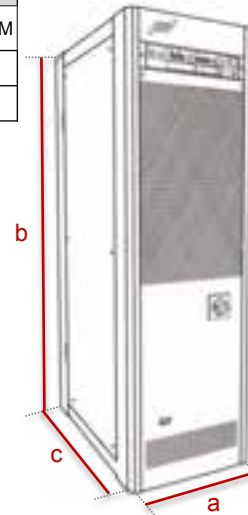

**Amplifier**  
Model: SA5M-J50  
a: W 580mm  
b: H 1950mm  
c: D 850mm

Model: SA5M-J50EM  
a: W 1160mm  
b: H 1950mm  
c: D 850mm

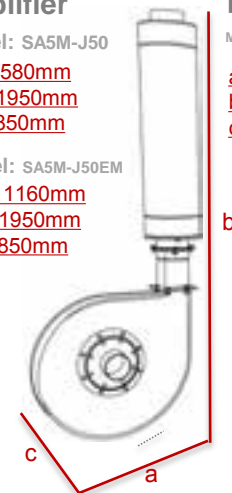

**Blower**  
Model: VAPE 710/P2R  
a: W 1160mm  
b: H 2405mm  
c: D 787mm

\*1) Power supply: 3-phase 200/220/240/380/400/415/440V, 50/60Hz.  
A transformer is required for other supply voltages.  
\*2) Random force ratings are specified in accordance with ISO5344 conditions.  
\*3) The specification shows the maximum system performance. For long-duration tests, de-rating by up to 70% must be applied. Continuous use at maximum levels may cause failure.  
\*4) In the case of Random vibration test, please set the test definition of the peak value of acceleration waveform to be operated less than the maximum acceleration of Shock.  
\*5) Above 2000 Hz, the force rolls-off at a rate of -12 dB/oct.  
\*6) Frequency range values vary according to sensor and vibration controller.  
\*7) Maximum velocity 4.6m/s. High velocity restricts maximum Shock force.  
Please contact IMV or your local distributor with specific test requirements.